



## Orion Minerals

ASX/JSE RELEASE: 22 October 2018

# Metallurgical Testwork Confirms Targeted Recoveries with Production of Saleable Zinc and Copper Concentrates at the Prieska Zinc-Copper Project

- ▶ **Completed testwork confirms metallurgical continuity across the Deep Sulphide Zone at Prieska.**
- ▶ **No material metallurgical zonation issues encountered.**
- ▶ **Excellent copper and zinc metal recoveries confirmed, in line with historical mine performance.**
- ▶ **Ability to produce high-quality, differentiated copper and zinc metal concentrates producible.**
- ▶ **Results will allow process plant design to proceed, as part of the Prieska BFS due in Q2 2019.**
- ▶ **Preliminary testwork shows potential to use safer and more environmentally-friendly froth-flotation chemical reagents, with added benefit of delivering cost reductions.**

### Orion's Managing Director and CEO, Errol Smart, commented:

*"We are very pleased to have shown conclusively that the extensions of the Prieska Deep Sulphide Zone targeted by our recently completed resource drilling are metallurgically identical to the ore that was treated with great success for over 20 years. This is an important result, which shows that we can expect to at least match and potentially exceed the historical plant performance and concentrate qualities.*

*The results from the locked-cycle testwork program confirms that we can include and use the historical mine metallurgical performance in the ongoing Bankable Feasibility Study, allowing us to complete the design of the process plant. We can now also provide potential concentrate off-take parties with target concentrate specifications including minor element analyses, confirming our ability to deliver high quality concentrates. The fact that we can produce concentrates with negligible levels of key contaminants such as manganese or lead in our zinc concentrates is a real plus for Orion as a new base metals producer.*

*The additional testwork findings also indicate that we can use modern reagents and exclude cyanide from the process, bringing both health and safety and environmental management benefits to the project while achieving likely capital and operating cost reductions."*

Orion Minerals Ltd (**ASX/JSE: ORN**) (**Orion**) is pleased to advise that it has successfully completed follow-up locked-cycle metallurgical testwork on the deeper mineralised domains (**Deep Sulphide Zone**) at its Prieska Zinc-Copper Project (**Prieska Project**), located in the Northern Cape Province of South Africa.

The Prieska Deep Sulphide Zone is currently the subject of a Bankable Feasibility Study (**BFS**) targeted for completion in Q2 2019. Initial results from the metallurgical testwork program were reported in June (refer ASX release 12 June 2018) and the program has now been completed. Results have confirmed the metallurgical continuity of the Deep Sulphide Zone with the up-dip area of the mineralised zone, where, in the period between 1971-1991, 45 million tonnes of ore were mined and successfully processed to produce clean and widely-marketed concentrates.

Excellent recoveries of both copper and zinc into separate, high-quality concentrates have been achieved using the froth-flotation process that was used in historical operations. In addition, the use of modern metallurgical reagents – which have advantages in terms of health and safety, environmental management as well as in potential capital and operating cost savings – is showing encouraging results.

### **Deep Sulphide Zone (Hypogene) Test Results**

The latest bench-scale, lock-cycle metallurgical tests have achieved targeted total metal recoveries, ranging from **80% to 94% for zinc** and **80% to 86% for copper** into separated concentrates.

The resultant concentrates had metal grades ranging between 45% and 54% for zinc and between 20% and 26% for copper in the respective products (refer Tables 1 and 2). Gold and silver are collected in the copper concentrates at levels that would qualify them as valuable by-products. Results are consistent with expectations for bench-scale test work, which has limited stabilisation time and hence still opportunity for improvement in continuous operation.

Detailed elemental analyses of the concentrates confirmed that several key deleterious elements are at negligible levels with, notably amongst others, arsenic, bismuth, cadmium, cobalt, tellurium, thorium and uranium at levels well below thresholds that may attract material penalty charges from most smelters or exclude some markets. Samples were obtained from across the extent of the deposit and composited into several blends such that a wide range of feed compositions could be assessed (refer to Table 3, Figures 5 and 6). Production scheduling using this information will further optimise resultant marketable products.

Test results to date have generally equalled or exceeded the metal recoveries and concentrate grades achieved during historical mining operations. When graphically superimposed over the historical plant performance dataset (refer to Figures 1 and 2 below), the latest locked-cycle test results (highlighted in red) compare favourably with the historical operational performance. The zinc and copper recovery results correlate well to the average historical trend line.

Mine records show that over the 20-year mine life, 1.01 million tonnes of zinc and 430,000 tonnes of copper were sold as separated, high-grade metal concentrates, with average metal recoveries of over 85% achieved for both metals, (refer ASX release 15 November 2017).

The latest metallurgical testing program validates this substantial historical dataset which now can be applied, along with more recent testwork results, to formulate base assumptions for ongoing mine feasibility studies and for concentrate marketing terms.

### **Processing Plant Design and Cyanide Substitution**

Metallurgical testing of the Prieska deposit is being conducted as part of an ongoing BFS. Outcomes from the work program now enable the next phase of the BFS to progress, which includes the final design of the metallurgical plant, derivation of metallurgical performance projections and optimisation of the reagent suite to improve operating efficiency and cost control. The mineral processing plant currently being designed employs a similar flowsheet to that used in historical mining operations, albeit with the application of modern technology while re-utilising as much of the remaining surface infrastructure as is serviceable.

Investigations into optimising the reagent suite for the mineral processing plant are in progress with the objective of, amongst others, substituting the use of sodium cyanide as a zinc depressant, with sodium metabisulfite (**SMBS**).

The removal of sodium cyanide from the reagent suite would have significant economic and safety benefits for the project, reducing the cost of production, avoiding any potential exposure to sodium cyanide and eliminating the need for a detoxification section of the plant ahead of tailings storage.

Preliminary tests indicate that SMBS can effectively provide similar performances to sodium cyanide. A Deep Sulphide Zone sample blend was tested using the standard froth-flotation flowsheet to produce

copper and zinc concentrates. The control test employed sodium cyanide, while several subsequent comparison tests used SMBS instead of the sodium cyanide.

Test conditions for the comparison tests were adjusted for each iteration and indications were that the SMBS reagent suite performed as well as the cyanide control test (refer to Figures 10 and 11). Further testwork is in progress to validate these early observations. The substitution of sodium cyanide with SMBS will be a significant improvement on the historically-applied mineral processing techniques and is in line with modern standard practice worldwide.

### Project Background

The Prieska Project is located in the Northern Cape Province of South Africa, approximately 290km south-west of the city of Kimberley, (Figure 3). The project area encompasses the historical Prieska Copper Mine (PCM). The PCM was profitably operated by Anglovaal as an underground zinc and copper mine, exploiting the Copperton deposit between 1971 and 1991, processing on average three million tonnes per year to produce 1.01 million tonnes of zinc and 430,000 tonnes of copper in concentrates (refer ASX release 15 November 2017). Run-of-mine ore was treated by froth flotation to produce separate concentrates of copper and zinc.

Orion is now investigating the establishment of new mining operations targeting the extraction of the remaining zinc-copper mineralisation at the Prieska volcanogenic massive sulphide (VMS) deposit.

Orion has delineated a global Mineral Resource, classified by a Competent Person and reported in accordance with the JORC Code (2012), amounting to 29.4 million tonnes grading 3.8% zinc and 1.2% copper, comprising, amongst others, a hypogene Inferred Mineral Resource of 27.8 million tonnes grading 3.9% zinc and 1.2% copper (**Deep Sulphide Zone**) (Figure 4) and a supergene Indicated Mineral Resource amounting to 1.2 million tonnes grading 2.6% zinc and 2.4% copper (**Supergene zone**) (refer ASX release 9 April 2018). Mineral Resource definition work is ongoing, with the objective of improving the classification of the Mineral Resource estimate as part of the BFS.

Mine development studies are scheduled for completion in the first half of 2019. DRA Projects South Africa Pty Ltd (DRA) is the lead consultant appointed to consolidate the BFS, part of which includes the design of the mineral processing plant. Metallurgical testwork is being conducted at the Mintek laboratories in Johannesburg, South Africa. ABS Africa Pty Ltd are supervising the environmental permitting.



Errol Smart  
Managing Director and CEO

### ENQUIRIES

#### Investors

Errol Smart – Managing Director & CEO

Denis Waddell – Chairman

T: +61 (0) 3 8080 7170

E: [info@orionminerals.com.au](mailto:info@orionminerals.com.au)

Suite 617, 530 Little Collins Street  
Melbourne, VIC, 3000

#### Media

Nicholas Read

Read Corporate, Australia

T: +61 (0) 419 929 046

E: [nicholas@readcorporate.com.au](mailto:nicholas@readcorporate.com.au)

#### JSE Sponsor

Rick Irving

Merchantec Capital

T: +27 (0) 11 325 6363

E: [rick@merchantec.co.za](mailto:rick@merchantec.co.za)

## Competent Person's Statement

The information as presented in this report that relates to the results of metallurgical test work at the Prieska Project is not in contravention of the 2012 Edition of the Australasian Code for Reporting of Exploration Results, Mineral Resources and Ore Reserves (**JORC Code**) and has been compiled and assessed under the supervision of Mr Errol Smart, Orion's Managing Director. Mr Smart (PrSciNat) is registered with the South African Council for Natural Scientific Professionals, a Recognised Overseas Professional Organisation (ROPO) for JORC purposes and has sufficient experience that is relevant to the style of mineralisation and type of deposit under consideration and to the activity being undertaken to qualify as a Competent Person as defined in the 2012 Edition of the JORC Code. Mr Smart consents to the inclusion in this announcement of the matters based on his information in the form and context in which it appears.

## Disclaimer

This release may include forward-looking statements. Such forward-looking statements may include, among other things, statements regarding targets, estimates and assumptions in respect of metal production and prices, operating costs and results, capital expenditures, mineral reserves and mineral resources and anticipated grades and recovery rates, and are or may be based on assumptions and estimates related to future technical, economic, market, political, social and other conditions. These forward-looking statements are based on management's expectations and beliefs concerning future events. Forward-looking statements inherently involve subjective judgement and analysis and are necessarily subject to risks, uncertainties and other factors, many of which are outside the control of Orion. Actual results and developments may vary materially from those expressed in this release. Given these uncertainties, readers are cautioned not to place undue reliance on such forward-looking statements. Orion makes no undertaking to subsequently update or revise the forward-looking statements made in this release to reflect events or circumstances after the date of this release. All information in respect of Exploration Results and other technical information should be read in conjunction with Competent Person Statements in this release (where applicable). To the maximum extent permitted by law, Orion and any of its related bodies corporate and affiliates and their officers, employees, agents, associates and advisers:

- disclaim any obligations or undertaking to release any updates or revisions to the information to reflect any change in expectations or assumptions;
- do not make any representation or warranty, express or implied, as to the accuracy, reliability or completeness of the information in this release, or likelihood of fulfilment of any forward-looking statement or any event or results expressed or implied in any forward-looking statement; and
- disclaim all responsibility and liability for these forward-looking statements (including, without limitation, liability for negligence).

## Appendix 1 – Deep Sulphide Zone Metallurgical Testwork

### Sample Collection and Preparation

Approximately 800kg of mineralised hypogene samples were collected from diamond drilling cores. Samples were collected from 7 holes drilled to obtain samples from across the full extent of the target mineralised zones (refer to Table 4 and Figures 4, 5 and 6). Additional samples from three more holes drilled in the south-western extent of the Deep Sulphide Zone are pending assessment as part of confirmatory variability testwork (refer to Figure 6).

Samples were then composited to make up blends to assess the effect of different zinc to copper ratios, as well as mixes of samples from different geographic locations within the Deep Sulphide Zone. Five different blends were prepared for this testwork program, (refer to Table 3).

### Deep Sulphide Zone Flowsheet

The recovery plant design flowsheet tested is based on a conventional crushing, milling and flotation process as was effectively used previously by the Prieska Copper Mine.

The copper laboratory flow-sheet includes bench-scale operation of the following main processes:

- Crushing and milling;
- Copper rougher flotation;
- Concentrate regrind;
- Copper cleaner flotation.

Refer to Figure 7 for the flowsheet schematic.

The zinc laboratory flowsheet includes bench-scale operation of the following main processes, with the feed being the copper rougher tails:

- Zinc rougher flotation;
- Concentrate regrind;
- Zinc cleaner flotation.

Refer to Figure 8 for the flowsheet schematic.

### Test Work Methodology

Laboratory-scale, open-circuit flotation tests were conducted in 1kg batches. Each sample was milled using a laboratory rod mill at 50% solids by mass to achieve a target grind of 70% passing 75 microns for the hypogene samples.

The milled slurry was then transferred into a 2.5 litre flotation cell, which was agitated using a Denver D12 flotation machine at an impellor speed of 1200 rpm. Depending on the feed mass, cleaner flotation testing was conducted in either a 1 litre or 2 litre flotation cell which was agitated using a Denver D12 flotation machine at an impellor speed of 1000 -1200 rpm. Concentrates were collected by scraping off the froth at 15 second intervals. All test products were then pulverised and assayed for arrange of elements including copper, lead, zinc, iron and sulphur using the ICP analysis method.

Locked-cycle testing involves repetitive batch flotation testing, whereby the open-circuit flotation test described is repeated five times using the re-cycled intermediate flotation streams. A product sample is collected at the end of each cycle for ICP analysis.

## Appendix 2 – Tables and Figures

Deep Sulphide Zone Copper Concentrate										
Element	Units of Measure	Historical Pilot Plant	Blend 1	Blend 2	Blend 3	Blend 4	Blend 6	Min	Max	Average
Cu	%	26.30	25.50	25.70	22.10	22.00	19.80	19.80	25.70	23.02
Zn	%	4.68	3.51	8.80	9.67	9.90	12.50	3.51	12.50	8.88
Fe	%	28.00	26.20	25.00	26.70	23.70	21.20	21.20	26.70	24.56
Total S	%	30.70	28.90	30.20	30.30	31.80	30.80	28.90	31.80	30.40
Ag	g/t	57.00	150.77	147.00	144.00	176.00	153.00	144.00	176.00	154.15
Au	g/t	2.80	3.33	2.56	2.01	2.40	2.80	2.01	3.33	2.62

**Table 1: Element analyses conducted on the differentiated copper concentrates produced from composite samples derived from the Deep Sulphide Zone, (refer to Table 4 for blend grades)**

Deep Sulphide Zone Zinc Concentrate									
Element	Unit of Measure	Historical Pilot Plant	Blend 1	Blend 2	Blend 3	Blend 4	Min	Max	Average
Zn	%	50.37	53.87	49.60	46.50	50.90	46.50	53.87	50.22
Cu	%	1.16	0.78	1.11	0.62	0.55	0.55	1.11	0.77
Fe	%	10.56	6.25	10.10	17.90 <sup>1</sup>	6.07	6.07	17.90	10.08
Total S	%	31.72	29.53	30.10	29.30	31.50	29.30	31.50	30.11
Ag	g/t	19.40	17.27	17.50	13.90	10.80	10.80	17.50	14.87
Au	g/t	1.40	0.52	0.35	0.33	0.29	0.29	0.52	0.37

**Table 2: Element analyses conducted on differentiated zinc concentrates produced from composite samples derived from the Deep Sulphide Zone, (refer to Table 4 for blend grades).**

Parameter	Units of Measure	Blend 1	Blend 2	Blend 3	Blend 4	Blend 6 <sup>2</sup>	Deep Sulphide Mineral Resources Grades <sup>3</sup>
<b>Composite Description</b> NW=North West zone SW= South West zone	<b>%Weight</b> <b>%Weight</b>	<b>50% NW</b> <b>50% SE</b>	<b>80% NW</b> <b>20% SE</b>	<b>100% NW</b> <b>0% SE</b>	<b>20% NW</b> <b>80% SE</b>	<b>80% NW</b> <b>20% SE</b>	<b>81% NW 19% SE</b>
Sample Grade - Cu	%	0.92	1.11	1.21	0.82	0.79	1.20
Sample Grade - Zn	%	4.47	3.89	3.64	4.81	3.14	3.90
Sample Grade - Fe	%	15.5	19.3	22.9	14.4	15.0	15.8
Grade Ratio (Zn/Cu)	Zn : Cu	4.86	3.49	3.00	5.90	3.99	3.25

**Table 3: Summary of blended variability composites from collected metallurgical samples and the reported Mineral Resources grades for the Deep Sulphide Zone.**

<sup>1</sup> Compositing sample was used to define the design envelope for handling iron grades variation. For the mean Deep Sulphide Zone iron grade of 15.8%, the correlated iron grade in concentrate would be 8.5% ± 2%, (Refer Table 4).

<sup>2</sup> Blend 6 produced results for the copper concentrate stage only and did not stabilise sufficiently to produce reliable results for the zinc circuit.

<sup>3</sup> Refer ASX releases 8 February 2018 and 9 April 2018.

Hole ID	Intersection ID	Tenement	Target	Core Size
OCOD046	OCOD046-D1	Repli	NW Deeps	BQ
	OCOD046-D2-1	Repli	NW Deeps	BQ
OCOD048	OCOD048-D2-6	Repli	NW Deeps	NQ
	OCOD048-D2-7	Repli	NW Deeps	NQ
OCOD065	OCOD065-D1-4	Repli	NW Deeps	NQ
	OCOD065-D1-5	Repli	NW Deeps	NQ
OCOD066	OCOD066-D2	Repli	NW Deeps	NQ
	OCOD066-D3	Repli	NW Deeps	NQ
OCOD068	OCOD068-D1	Repli	NW Deeps	NQ
OCOD074	OCOD074-D1	Repli	SW Deeps	NQ
OCOD072	OCOD072-D1	Vardocube	SW Deeps	NQ
OCOD122	OCOD122-D2	Vardocube	SW Deeps	NQ
	OCOD122-D3	Vardocube	SW Deeps	NQ
OCOD134	OCOD134-D1	Vardocube	SW Deeps	NQ
OCOD135	OCOD135-D1	Vardocube	SW Deeps	NQ

Table 4: List of diamond drill holes from which metallurgical testing samples were extracted.

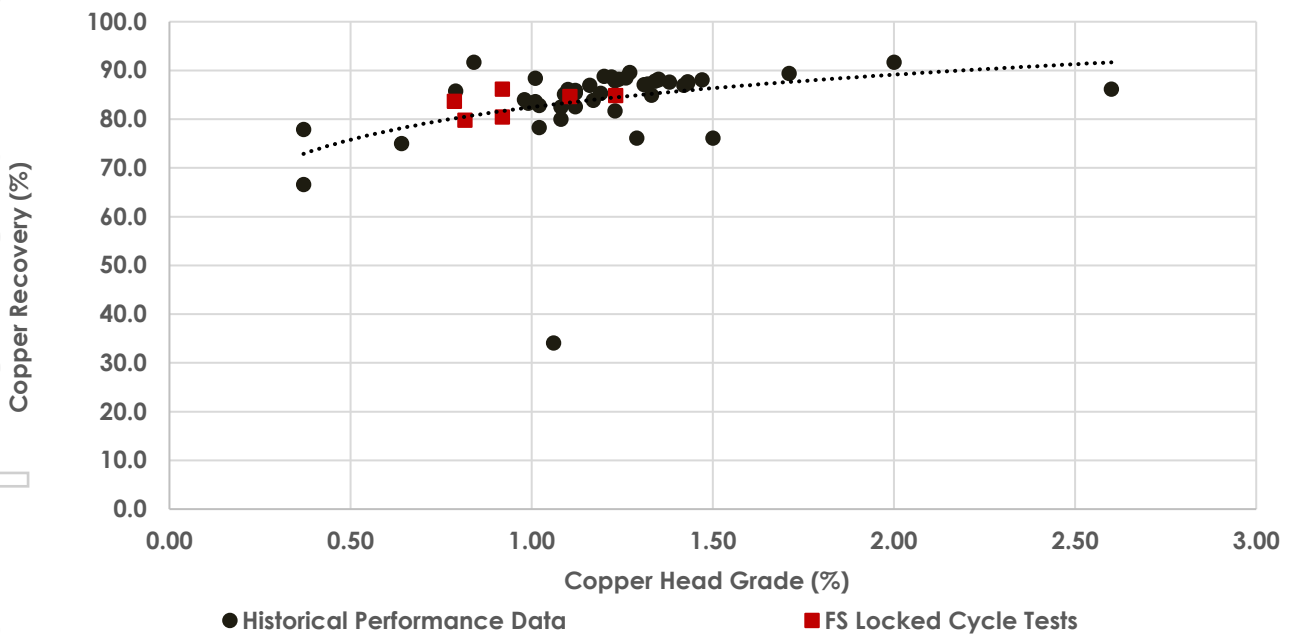

Figure 1: The graph shows the copper results for the FS locked-cycle test-work in red compared to the historical plant production and 1972 pilot plant results in black ('Historical Operational Data')<sup>4,5</sup>, during 1970 Anglovaal pilot plant testing ('Pilot Plant (1970)').

<sup>4</sup> Averaged Monthly Production Data (January 1975 – December 1976), Brian Broekman 1991, The Prieska experience: Flotation developments in copper-zinc separation, J.S. Afr. Inst. Min. Metal., vol. 91, no. 8. Aug. 1991. pp. 257-265.

<sup>5</sup> S.K De Kok 1972, Differential Flotation of Copper-Zinc at Prieska Copper Mines (Pty) Limited: A Pre-Liminary Report, Journal of the South African Institute of Mining and Metallurgy July 1972. pp. 305 – 321.

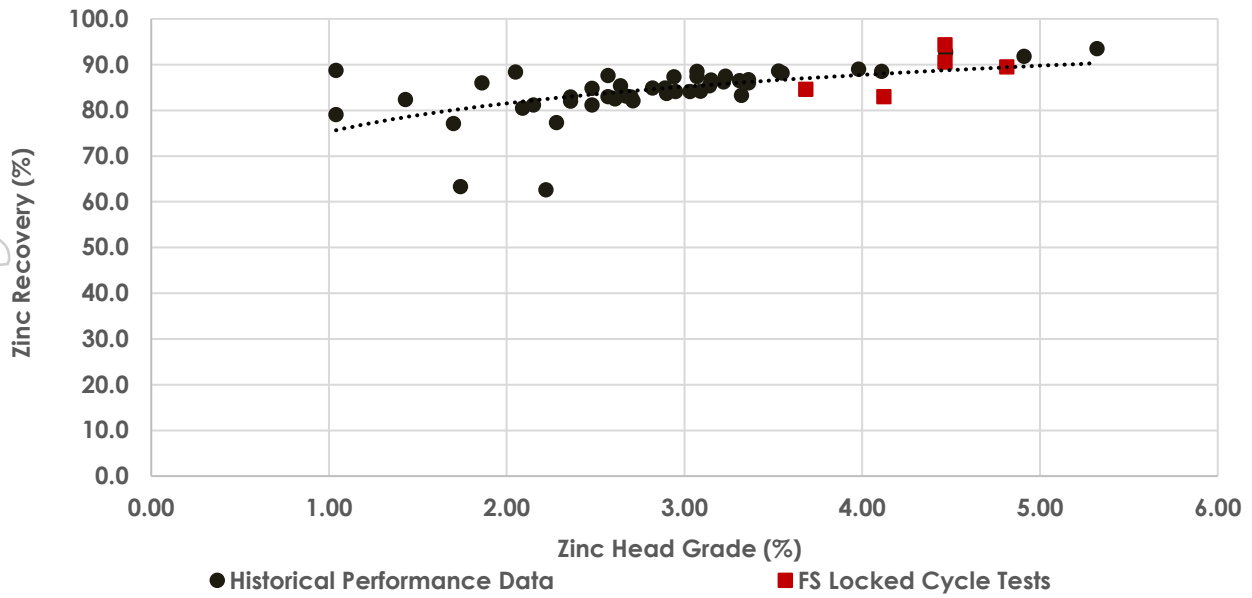

Figure 2: The graph shows the zinc results for the FS locked-cycle test-work in red compared to the historical plant production and 1972 pilot plant results in black ('Historical Operational Data')<sup>1,6</sup>, during 1970 Anglovaal pilot plant testing ('Pilot Plant (1970)').



Figure 3: Location of the Prieska Zinc Copper Project in the Northern Cape Province, South Africa

<sup>6</sup> Averaged Annual Production Data 1973 – 1991 extracted from: Technical Report on the Copperton Project of Repli Trading No 27 (Pty) Ltd, March 2014.



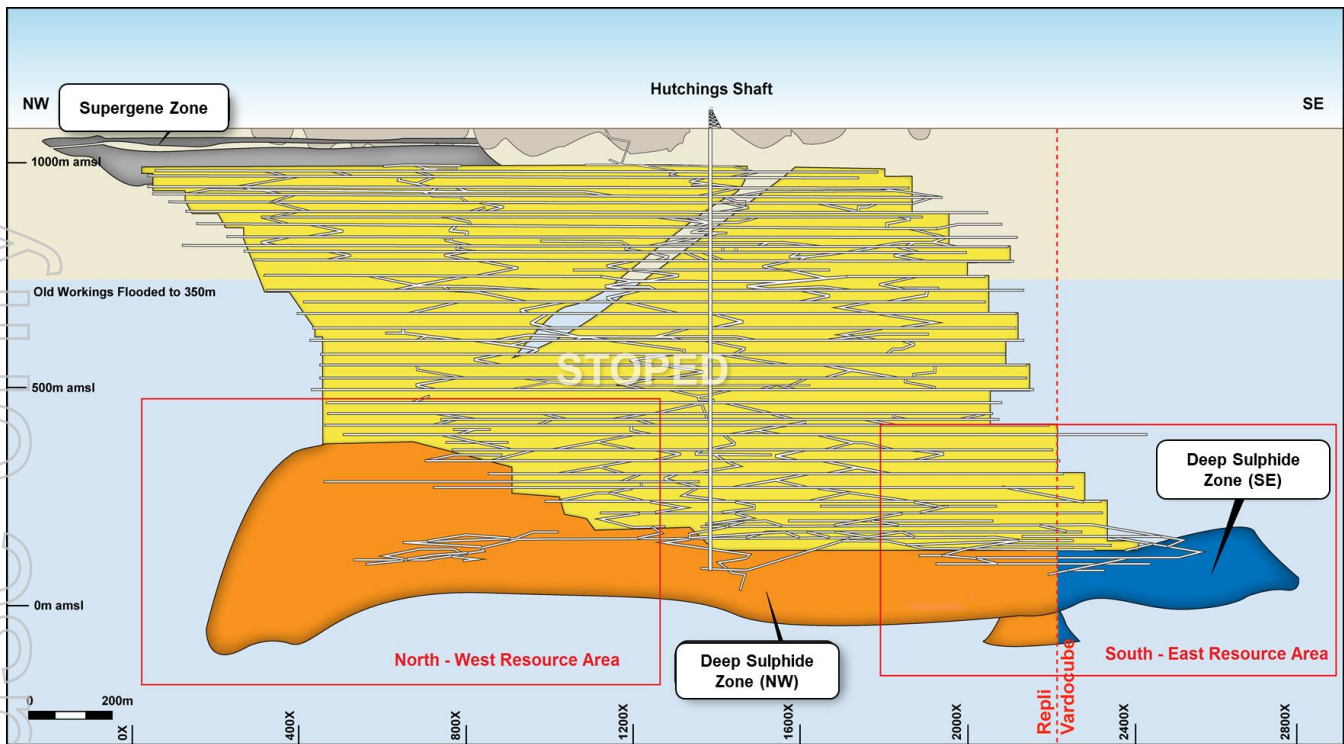

Figure 4: Long-section of Prieska deposit showing the location of the Deep Sulphide Zone (in orange and dark blue). The areas of the Deep Sulphide Zone that are targeted for the initial phase of mine planning are demarcated inside the red rectangular outlines as the North-West Resource Area and the South East Resource Area.

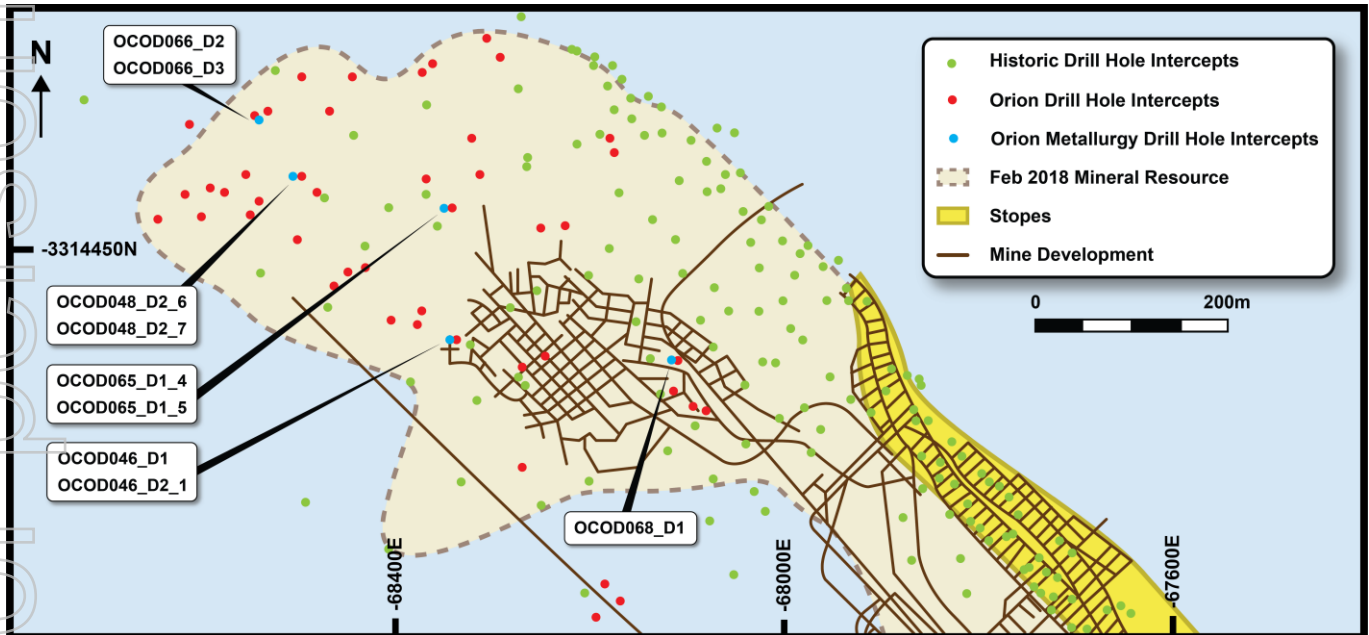

Figure 5: Plan view showing the North-West extent of the Deep Sulphide Zone (North-West resource Area) outline of the Prieska Project, showing diamond drill hole intersection points, including drill hole intersections for metallurgical samples reported in this release.

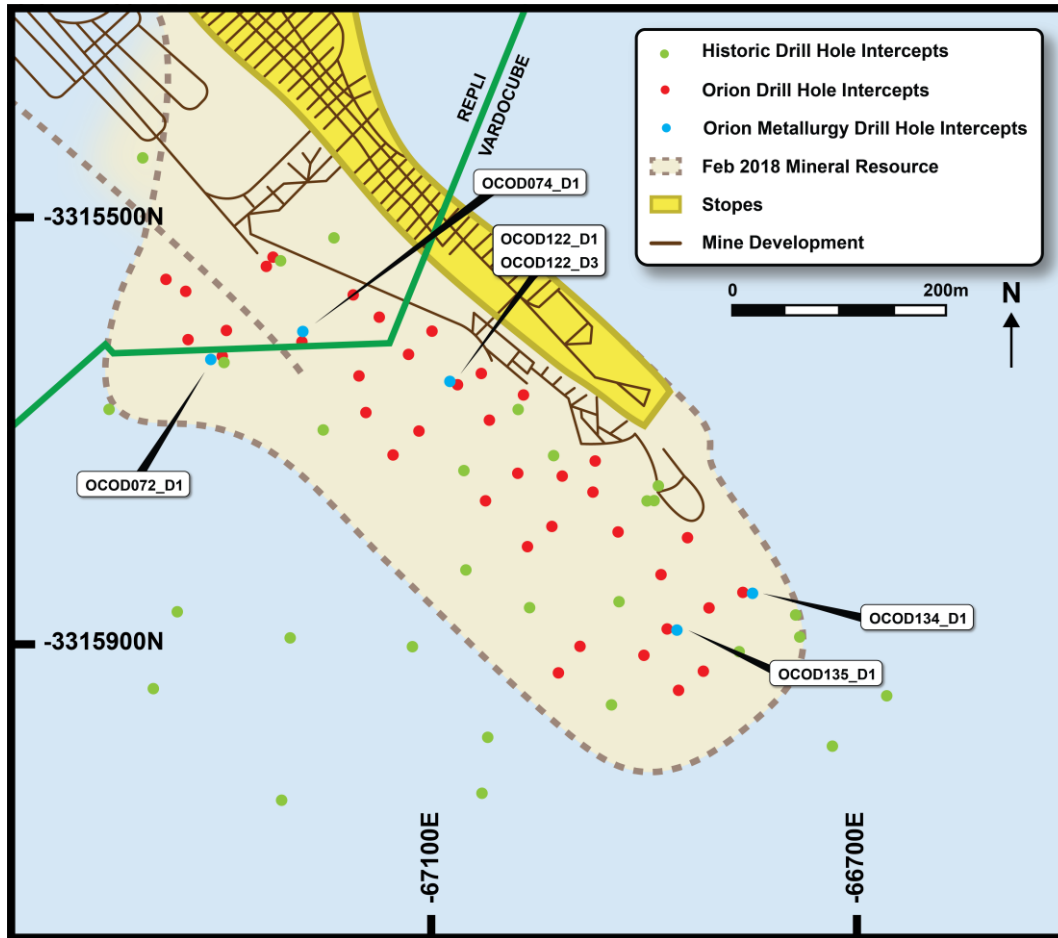

Figure 6: Plan view showing the South-East extent of the Deep Sulphide Zone (South-East resource Area) outline of the Prieska Project, showing diamond drill hole intersection points, including drill hole intersections for metallurgical samples reported in this release.

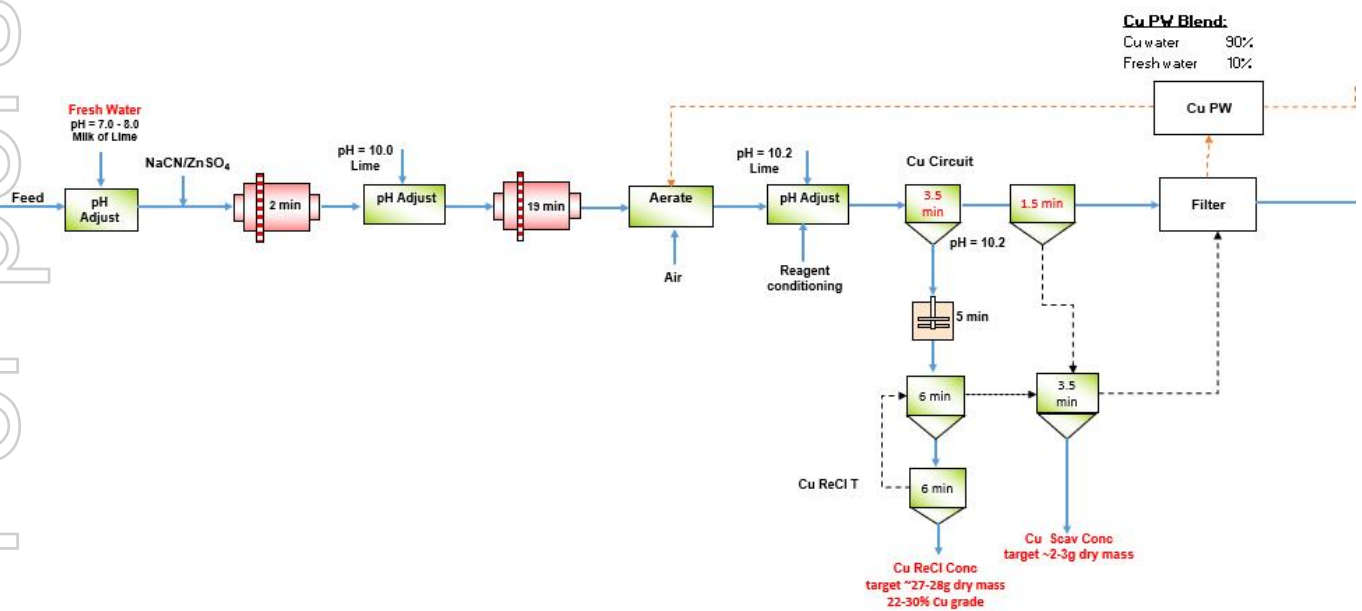

Figure 7: Lock-cycle testwork flowsheet showing the copper concentrate production step.

For personal use only

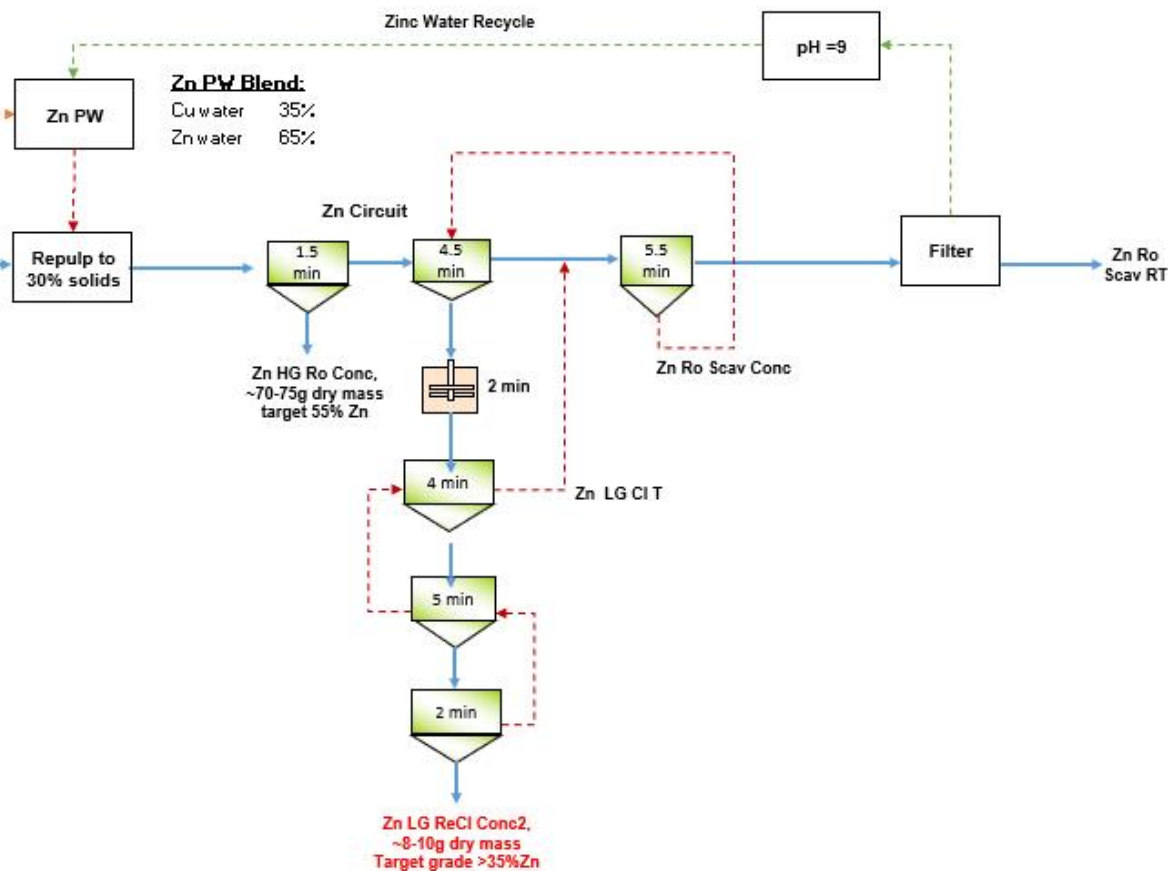

Figure 8: Lock-cycle testwork flowsheet showing the zinc concentrate production step.

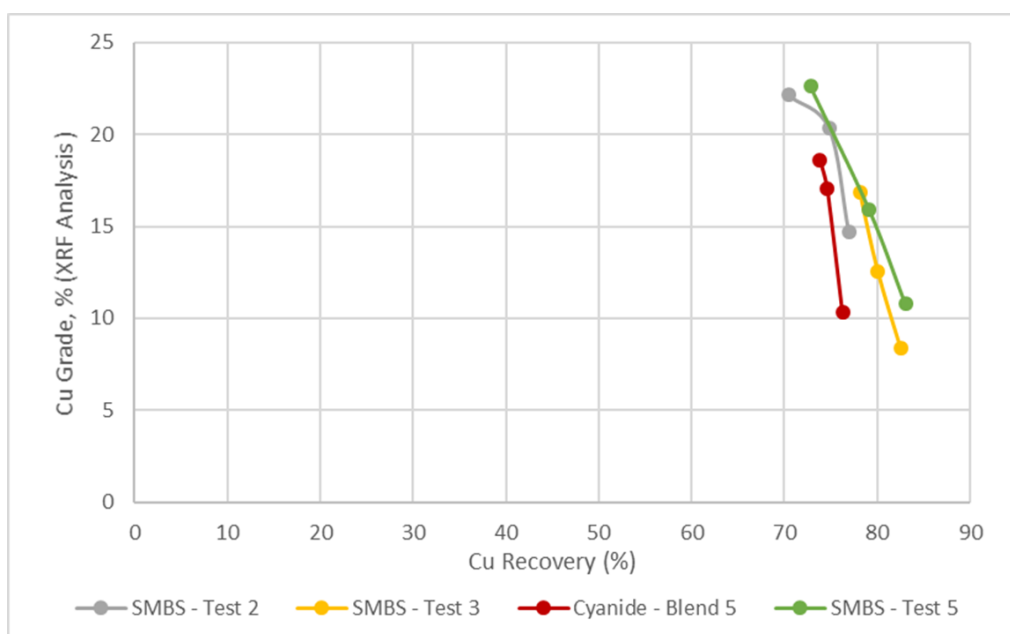

Figure 9: Copper concentrate grade versus metal recovery graph showing the upgrade profile of Blend 5 sample using sodium cyanide (red) and using SMBS (Test 2,3, and 5). The results show that the upgrade profile when using SMBS only is comparable to that of when using sodium cyanide. Note that results are preliminary and further testwork is in progress.

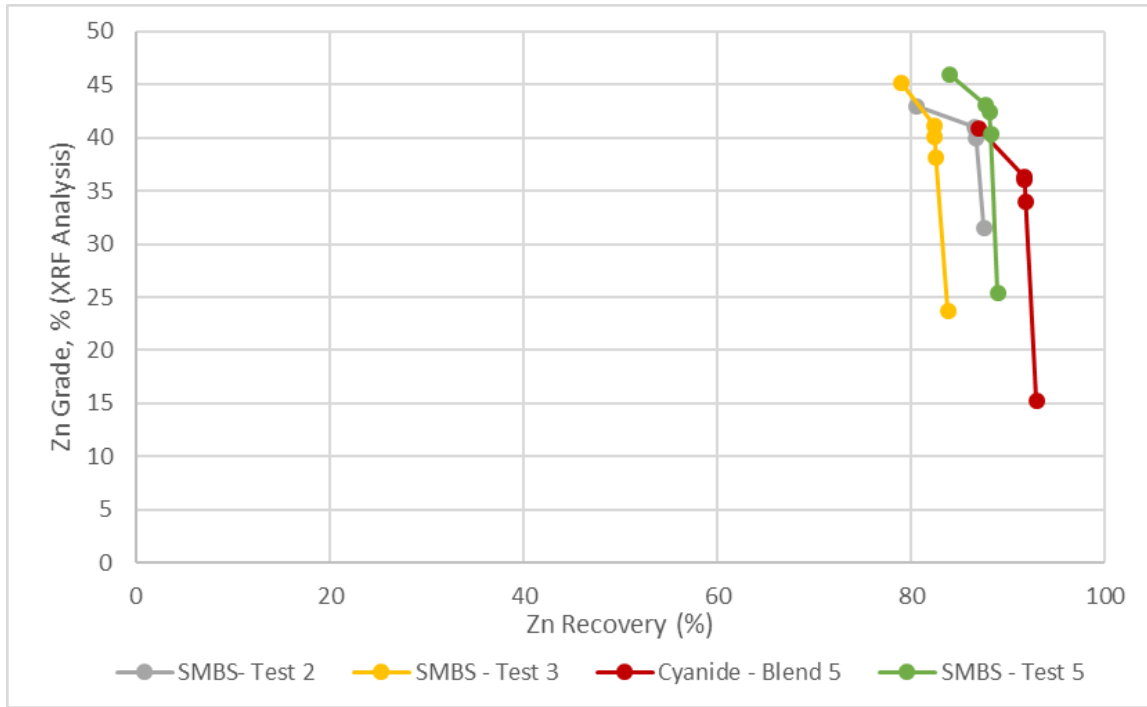

Figure 10: Zinc concentrate grade versus metal recovery graph showing the upgrade profile of Blend 5 sample using sodium cyanide (red) and using SMBS (Tests 2,3, and 5). The results show that the upgrade profile when using SMBS only is comparable to that of when using sodium cyanide. Note that results are preliminary and further testwork is in progress.

Appendix 3: The following tables are provided in accordance with the JORC Code (2012) for the reporting of Exploration Results for Prieska Project.

Section 1 Sampling Techniques and Data

(Criteria in this section apply to all succeeding sections.)

Criteria	JORC Code explanation	Commentary
<p><b>Sampling techniques</b></p>	<ul style="list-style-type: none"> <li>Nature and quality of sampling (e.g. cut channels, random chips, or specific specialised industry standard measurement tools appropriate to the minerals under investigation, such as down hole gamma sondes, or handheld XRF instruments, etc.). These examples should not be taken as limiting the broad meaning of sampling.</li> <li>Include reference to measures taken to ensure sample representivity and the appropriate calibration of any measurement tools or systems used.</li> <li>Aspects of the determination of mineralisation that are Material to the Public Report.</li> <li>In cases where 'industry standard' work has been done this would be relatively simple (e.g. 'reverse circulation drilling was used to obtain 1 m samples from which 3 kg was pulverised to produce a 30 g charge for fire assay'). In other cases more explanation may be required, such as where there is coarse gold that has inherent sampling problems. Unusual commodities or mineralisation types (e.g. submarine nodules) may warrant disclosure of detailed information.</li> </ul>	<ul style="list-style-type: none"> <li>Drilling and sampling has been undertaken during three distinct periods since the discovery of mineralisation. These are pre-mine exploration (1968-1971) and during mine operations (1972-1984) holes ("V", "D", and "F" prefixed holes) by Anglovaal Ltd (also known as the Anglovaal Group, "Anglovaal"), and current drilling (2017 to present) by Orion Minerals Ltd (<b>Orion</b>).</li> </ul> <p>Anglovaal:</p> <ul style="list-style-type: none"> <li>For diamond drilling carried out by Anglovaal between 1968 and 1984, there is limited information available on sampling techniques for core. However, with exploration and resource management being carried out under the supervision of Anglovaal, it is considered by the Competent Person that there would be procedures in place to industry best practice standard at that time. This is based on the Competent Persons knowledge of exploration carried out by Anglovaal and discussions with personnel employed by Anglovaal.</li> <li>The exploration and resource management were under the professional supervision of Dr Danie Krige an internationally recognised expert of the time who published peer reviewed papers based on the sampling data. The sampling was successful in defining a resource estimate which was used as the basis of successful mine development and operation over a 20-year period.</li> <li>Drilling of the original surface exploration holes was carried out 200m – 250m line spacing. Underground exploration holes were not drilled on a regular spacing.</li> <li>Surface drill exploration samples were all sent to Anglovaal Research Laboratory at Rand Leases Mine and underground drill samples to the mine laboratory for analyses.</li> <li>No records on the sampling methodology used are available.</li> </ul> <p>Orion:</p> <ul style="list-style-type: none"> <li>Diamond core is cut at the core yard and half core is taken as the sample.</li> <li>The core is sampled at 1 m intervals where possible with sample lengths adjusted to ensure samples do not cross geological boundaries or other features.</li> <li>Drilling at the Deep Sulphide Target was carried out with the aim of defining an approximate 60m x 60m pattern by use of "mother" holes</li> </ul>

Criteria	JORC Code explanation	Commentary
		<p>and deflections therefrom.</p> <ul style="list-style-type: none"> <li>• Mineralised zones are drilled using core drilling.</li> <li>• Sampling is carried out under supervision of a qualified geologist using procedures outlined below including industry standard QA/QC.</li> <li>• Samples submitted for analysis to ALS Chemex (Pty) Ltd (<b>ALS</b>) are pulverised in its entirety at ALS and split to obtain a 0.2g sample for digestion and analysis.</li> <li>• Metallurgical samples were submitted to MINTEK for testwork and analysis.</li> <li>• Metallurgical samples were composited to form blends to allow variability testing. The individual Hypogene (Deeps) variability drill core samples were used to make-up the variability blend composites. The individual variability drill core samples were stage crushed to 100% passing 1.7mm, thoroughly blended and split into representative subsamples by means of a rotary splitter. Variability blend composites were produced by blending the required mass of each of the individual drill core composites before blending and splitting into 1kg representative subsamples by means of a rotary splitter.</li> <li>• The Mintek analytical services division is ISO 17025 accredited and runs a QA/QC program to verify the analysis precision and repeatability using SARM control charts. All the samples are analysed with certified reference material (<b>CRM</b>) with known values.</li> </ul>
<b>Drilling techniques</b>	<ul style="list-style-type: none"> <li>• <i>Drill type (e.g. core, reverse circulation, open-hole hammer, rotary air blast, auger, Bangka, sonic, etc.) and details (e.g. core diameter, triple or standard tube, depth of diamond tails, face-sampling bit or other type, whether core is oriented and if so, by what method, etc.).</i></li> </ul>	<p>Anglovaal:</p> <ul style="list-style-type: none"> <li>• Records for core size are not available.</li> <li>• No record on core orientation.</li> </ul> <p>Orion:</p> <ul style="list-style-type: none"> <li>• Diamond core drilling using NQ and BQ sized core. BQ core was only drilled where problems were encountered in the original NQ drilled drill hole and the drilling could not continue with NQ size.</li> <li>• In the near-surface weathered zone HQ core was drilled.</li> <li>• Pre-collar drilled using percussion drilling on certain holes (above mineralisation).</li> <li>• Core was orientated in holes selected for geotechnical studies.</li> </ul>
<b>Drill sample recovery</b>	<ul style="list-style-type: none"> <li>• <i>Method of recording and assessing core and chip sample recoveries and results assessed.</i></li> <li>• <i>Measures taken to maximise sample recovery and ensure representative nature of the samples.</i></li> <li>• <i>Whether a relationship exists between sample recovery and grade and whether sample bias may have occurred due to preferential loss/gain of fine/coarse material.</i></li> </ul>	<p>Anglovaal:</p> <ul style="list-style-type: none"> <li>• All mineralised intersections were done with core drilling.</li> <li>• Core recoveries are documented on the assay sheets. Core recoveries were measured for each "run".</li> <li>• In most V holes and all D and F holes, intersections were in hard rock and recoveries were generally good through the mineralisation.</li> </ul>

Criteria	JORC Code explanation	Commentary
		<p>Orion:</p> <ul style="list-style-type: none"> <li>All mineralised intersections are done with core drilling.</li> <li>Core stick-ups reflecting the depth of the drill hole are recorded at the rig at the end of each core run.</li> <li>A block with the depth of the hole written on it is placed in the core box at the end of each run.</li> <li>At the core yard, the length of core in the core box is measured for each run. The measured length of core is subtracted from the length of the run as recorded from the stick-up measured at the rig to determine the core lost.</li> <li>Core recovery in all the mineralised intersections are good.</li> <li>No grade variation with recovery was noted.</li> </ul>
<b>Logging</b>	<ul style="list-style-type: none"> <li>Whether core and chip samples have been geologically and geotechnically logged to a level of detail to support appropriate Mineral Resource estimation, mining studies and metallurgical studies.</li> <li>Whether logging is qualitative or quantitative in nature. Core (or costean, channel, etc.) photography.</li> <li>The total length and percentage of the relevant intersections logged.</li> </ul>	<p>Anglovaal:</p> <ul style="list-style-type: none"> <li>All relevant intersections for V surface holes have been geologically logged by qualified geologists and all of this information is available. It is understood from historical reports and discussions with Anglovaal geologists involved with the Prieska Mine that all intersections for D and F holes were logged by qualified geologists. The detail logs are currently not available.</li> <li>Downhole geotechnical information is available for some of the D and F holes only. Downhole mineralogical logs are available for some D and F holes.</li> </ul> <p>Orion:</p> <ul style="list-style-type: none"> <li>Pre-collar percussion holes are logged by qualified geologists on 1m intervals using visual inspection of washed drill chips. A hand held XRF instrument is used to determine the presence of any metals.</li> <li>Core of the entire hole length was geologically logged and recorded on standardised log sheets by qualified geologists.</li> <li>Qualitative logging of colour, grain size, weathering, structural fabric, lithology, alteration type and sulphide mineralogy carried out.</li> <li>Quantitative estimate of sulphide mineralogy.</li> <li>Logs are recorded at the core yard and entered into digital templates at the project office.</li> </ul>
<b>Sub-sampling techniques and sample preparation</b>	<ul style="list-style-type: none"> <li>If core, whether cut or sawn and whether quarter, half or all core taken.</li> <li>If non-core, whether riffled, tube sampled, rotary split, etc. and whether sampled wet or dry.</li> <li>For all sample types, the nature, quality and appropriateness of the sample preparation technique.</li> <li>Quality control procedures adopted for all sub-sampling stages to</li> </ul>	<p>Anglovaal:</p> <ul style="list-style-type: none"> <li>Details of sub-sampling techniques not available.</li> <li>Although no formal QC samples were inserted by the geologists at the time of drilling the Anglovaal Research Laboratory produced their own standards, certified by other commercial laboratories which were routinely inserted into batches at the laboratory. Duplicate samples were</li> </ul>

Criteria	JORC Code explanation	Commentary
	<p><i>maximise representivity of samples.</i></p> <ul style="list-style-type: none"> <li>Measures taken to ensure that the sampling is representative of the in situ material collected, including for instance results for field duplicate/second-half sampling.</li> <li>Whether sample sizes are appropriate to the grain size of the material being sampled.</li> </ul>	<p>also inserted to check for repeatability.</p> <p>Orion:</p> <ul style="list-style-type: none"> <li>Samples from percussion pre-collars are collected by spear sampling.</li> <li>Sampling on site aims to generate a &lt; 2kg sub sample to enable the entire sample to be pulverised without further splitting.</li> <li>Water is used in the dust depression process during percussion drilling, resulting in wet chip samples.</li> <li>BQ and NQ core cut at core yard and half core taken as sample.</li> <li>With core samples, the entire sample length is cut and sampled.</li> <li>Sample preparation is undertaken at ALS, an ISO accredited laboratory. ALS utilises industry best practise for sample preparation for analysis, involving drying of samples, crushing to &lt;5mm if required and then pulverising so that +85% of the sample passes 75 microns.</li> <li>CRMs, blanks and duplicates are inserted and analysed with each batch. Insertion rates for the current reporting is: CRMs = 10%, blanks = 5% and field duplicates = 2%.</li> </ul>
<p><b>Quality of assay data and laboratory tests</b></p>	<ul style="list-style-type: none"> <li>The nature, quality and appropriateness of the assaying and laboratory procedures used and whether the technique is considered partial or total.</li> <li>For geophysical tools, spectrometers, handheld XRF instruments, etc., the parameters used in determining the analysis including instrument make and model, reading times, calibrations factors applied and their derivation, etc.</li> <li>Nature of quality control procedures adopted (e.g. standards, blanks, duplicates, external laboratory checks) and whether acceptable levels of accuracy (i.e. lack of bias) and precision have been established.</li> </ul>	<p>Anglovaal:</p> <ul style="list-style-type: none"> <li>Surface drill exploration samples were all sent to Anglovaal Research Laboratory at Rand Leases Mine.</li> <li>Underground drill hole samples were sent to the mine laboratory, where the same analytical method was used.</li> <li>Atomic Adsorption method was used with a Nitric-bromide digest. Underground drill hole samples were sent to the mine laboratory, where the same analytical method was used.</li> <li>Although no formal QC samples were inserted with the drill samples of the exploration holes the Anglovaal Research Laboratory developed their own standards, certified by other commercial laboratories and those were used internally in the laboratory. Duplicate samples were also inserted to check for repeatability.</li> </ul> <p>Orion:</p> <ul style="list-style-type: none"> <li>Samples submitted to ALS were analysed for base metals, Au and Ag. Analysis was by the Inductively Coupled Plasma and Optical Emission Spectroscopy ("ICP-OES") methodology, using a four-acid digest.</li> <li>External quality control of the laboratory assays is monitored by the insertion of blanks and CRMs.</li> <li>CRM samples show high accuracy and tight precision with no consistent bias.</li> <li>Blank samples indicate no contamination, within the pre-determined thresholds, during the sample preparation process.</li> <li>Laboratory samples show excellent accuracy and precision.</li> </ul>



Criteria	JORC Code explanation	Commentary
		<ul style="list-style-type: none"> <li>ALS has their own internal QC protocols which include CRMs (5%), blanks (2.5%) and duplicates (2.5%).</li> <li>External laboratory checks have been carried out.</li> <li>Metallurgical samples submitted to MINTEK and ICP-OES methodology applied for assaying.</li> <li>The Mintek analytical services division is ISO 17025 accredited and runs a QA/QC program to verify the analysis precision and repeatability using SARM control charts. All the samples are analysed with CRM with known values.</li> </ul>
<b>Verification of sampling and assaying</b>	<ul style="list-style-type: none"> <li>The verification of significant intersections by either independent or alternative company personnel.</li> <li>The use of twinned holes.</li> <li>Documentation of primary data, data entry procedures, data verification, data storage (physical and electronic) protocols.</li> <li>Discuss any adjustment to assay data.</li> </ul>	<p>Anglovaal:</p> <ul style="list-style-type: none"> <li>No records available.</li> </ul> <p>Orion:</p> <ul style="list-style-type: none"> <li>The Competent Person is personally supervising the drilling and sampling along with a team of experienced geologists.</li> <li>The Competent Person reviewed the calculation of the significant intersections.</li> <li>Twin holes are drilled to verify historical drill intersections (Anglovaal).</li> <li>For the EM survey, data are collected on site and validated by a geophysical technician daily. Data (raw and processed) is sent to a consultant geophysicist for review and quality control.</li> <li>No adjustments have been made to the assay data.</li> </ul>
<b>Location of data points</b>	<ul style="list-style-type: none"> <li>Accuracy and quality of surveys used to locate drill holes (collar and down-hole surveys), trenches, mine workings and other locations used in Mineral Resource estimation.</li> <li>Specification of the grid system used.</li> <li>Quality and adequacy of topographic control.</li> </ul>	<p>Anglovaal:</p> <ul style="list-style-type: none"> <li>All surface and underground hole collars were surveyed by qualified surveyors using a theodolite.</li> <li>The historic mine survey data is in the old national Lo23 Clarke 1880 coordinate system.</li> <li>Downhole surveys were carried out for most of the V holes and all of the D and F holes. Methodology of the downhole surveys is not recorded on the available hardcopy information but plans and sections are meticulously plotted and signed off by a certified surveyor.</li> <li>Both Eastman and Sperry Sun instruments were used in the downhole surveys.</li> <li>Significant deflections in the dips of the holes have been noted, especially for the deeper holes. V holes with no downhole surveys are shallower holes drilled earlier on in the initial exploration phase. These holes intersected areas where the mineralisation is now largely mined out.</li> <li>All hole positions have been converted to Lo23 WGS84 coordinates.</li> <li>Underground D and F holes are recorded in local "V" line and "O" distance coordinates with local mine datum elevations. Level plans have</li> </ul>

Criteria	JORC Code explanation	Commentary
		<p>both the local V/O grid and Lo23 Clark 1880 grids plotted and this has been used to define transformation parameters from local grid to geographical coordinates. All hole positions have been converted to Lo23 WGS84 coordinates.</p> <p>Orion:</p> <ul style="list-style-type: none"> <li>• Drill hole collar positions are laid out using a handheld GPS.</li> <li>• After completion of the Orion drilling all collars were surveyed by a qualified surveyor using a Trimble R8 differential GPS.</li> <li>• Downhole surveys are completed using a North-Seeking Gyro instrument.</li> <li>• All survey data is in the WGS84 ellipsoid in the WG23 Zone with the Hartebeeshoek 1994 Datum. The coordinates are also supplied in Clarke 1880 and in UTM WGS84 Zone 34 (Southern Hemisphere).</li> </ul>
<b>Data spacing and distribution</b>	<ul style="list-style-type: none"> <li>• Data spacing for reporting of Exploration Results.</li> <li>• Whether the data spacing and distribution is sufficient to establish the degree of geological and grade continuity appropriate for the Mineral Resource and Ore Reserve estimation procedure(s) and classifications applied.</li> <li>• Whether sample compositing has been applied.</li> </ul>	<p>Anglovaal:</p> <ul style="list-style-type: none"> <li>• Original exploration holes (V) were drilled on 200m - 250m spacing.</li> <li>• Underground drilled holes (D, F and R) were not drilled on a regular spaced grid.</li> </ul> <p>Orion:</p> <ul style="list-style-type: none"> <li>• At the Deep Sulphide Target drill holes aim to intersect mineralisation on spacings sufficient to establish geological and grade continuity appropriate for Mineral Resource and Ore Reserve estimations.</li> <li>• Variography studies were carried out on both the historic and Orion data set to determine the drill spacing for Mineral Resource estimates.</li> <li>• No sample compositing was applied.</li> </ul>
<b>Orientation of data in relation to geological structure</b>	<ul style="list-style-type: none"> <li>• Whether the orientation of sampling achieves unbiased sampling of possible structures and the extent to which this is known, considering the deposit type.</li> <li>• If the relationship between the drilling orientation and the orientation of key mineralised structures is considered to have introduced a sampling bias, this should be assessed and reported if material.</li> </ul>	<ul style="list-style-type: none"> <li>• Historical and current drilling is oriented perpendicular, or at a maximum achievable angle to, the attitude of the mineralisation.</li> <li>• As a result, most holes intersect the mineralisation at an acceptable angle.</li> <li>• No sampling bias is anticipated as a result of hole orientations.</li> <li>• EM surveys by Orion were completed in an orientation perpendicular to the interpreted or intersected mineralisation.</li> </ul>
<b>Sample security</b>	<ul style="list-style-type: none"> <li>• The measures taken to ensure sample security.</li> </ul>	<p>Anglovaal:</p> <ul style="list-style-type: none"> <li>• No details of sample security available. However, during the mining operations the site was fenced and gated with security personnel employed as part of the staff.</li> </ul> <p>Orion:</p> <ul style="list-style-type: none"> <li>• Chain of custody is managed throughout, and the policy managed through an appropriate SOP. Samples are stored on site in a secure</li> </ul>

Criteria	JORC Code explanation	Commentary
		locked building and then freighted directly to the laboratory.
<b>Audits or reviews</b>	<ul style="list-style-type: none"> <li>The results of any audits or reviews of sampling techniques and data.</li> </ul>	<p>Anglovaal:</p> <ul style="list-style-type: none"> <li>No records available.</li> </ul> <p>Orion:</p> <ul style="list-style-type: none"> <li>SRK Consulting has carried out a review on the sampling techniques and data.</li> </ul>

## Section 2 Reporting of Exploration Results

(Criteria listed in the preceding section also apply to this section.)

Criteria	JORC Code explanation	Commentary
<b>Mineral tenement and land tenure status</b>	<ul style="list-style-type: none"> <li>Type, reference name/number, location and ownership including agreements or material issues with third parties such as joint ventures, partnerships, overriding royalties, native title interests, historical sites, wilderness or national park and environmental settings.</li> <li>The security of the tenure held at the time of reporting along with any known impediments to obtaining a licence to operate in the area.</li> </ul>	<ul style="list-style-type: none"> <li>The Prospecting Rights are held by Repli Trading No 27 (Pty) Ltd and Vardocube (Pty) Ltd, which are subsidiaries of Orion.</li> <li>The Prospecting Right areas covers a strike of 2460m for the Deep Sulphide mineralisation.</li> <li>All of the required shaft infrastructure and lateral access underground development is available within the two Prospecting Rights.</li> </ul>
<b>Exploration done by other parties</b>	<ul style="list-style-type: none"> <li>Acknowledgment and appraisal of exploration by other parties.</li> </ul>	<ul style="list-style-type: none"> <li>All exploration and life of mine drilling (V, D and F holes) was done by Anglovaal, resulting in a substantial amount of hard copy data from which Orion has been able to assess the prospectivity of the remaining mineralisation.</li> <li>The Anglovaal exploration resulted in the delineation and development of a large mine.</li> <li>Metallurgical testwork was supervised by DRA Projects South Africa (Pty) Ltd (DRA) and most of the laboratory work conducted by MINTEK in their Johannesburg laboratories, South Africa.</li> </ul>
<b>Geology</b>	<ul style="list-style-type: none"> <li>Deposit type, geological setting and style of mineralisation.</li> </ul>	<ul style="list-style-type: none"> <li>The Copperton deposit is a Volcanogenic Massive Sulphide (<b>VMS</b>) deposit which is situated in the southernmost exposures of the north-northwest trending Kakamas Terrain, which forms part of the Mid-Proterozoic Namaqualand Metamorphic Complex.</li> <li>The deposit is hosted by the Copperton Formation of the Areachap Group. The Areachap Group, also hosts several other but smaller VMS deposits such as the Areachap, Boks Puts, Kantien Pan, Kielder, and Annex Vogelstruisbult deposits.</li> <li>The structural sequence at the mine consists of a footwall Smouspan Gneiss Member, Prieska Copper Mines Assemblage (PCMA), which hosts the sulphide mineralisation, and the hangingwall Vogelstruisbult Gneiss Member.</li> </ul>

Criteria	JORC Code explanation	Commentary
		<ul style="list-style-type: none"> <li>The historically mined section of the deposit is confined to a tabular, stratabound horizon in the northern limb of a refolded recumbent synform, the axis of which plunges at approximately 5° to the south-east.</li> <li>The mineralised zone outcrop has a strike of 2400m, is oxidised and / or affected by leached and supergene enrichment to a depth of approximately 100m and crops out as a well-developed gossan. It has a dip of between 55° and 80° to the northeast at surface and a strike of 130° to the north. Current drilling indicates that the Deep Sulphides has a strike length of at least 2860m in depth.</li> <li>The thickness of the mineralised zone exceeds 30m in places but averages between 7m and 9m. The mineralised zone persists to a depth of 1100m (as deep as 1228m in one section) after which it is upturned due to the folding.</li> <li>The Deep Sulphide Target area located below the historical mined area, comprises the steep down dip continuity ("steep limb and hinge zone") and from where it upturns to its subsequent synformal structure ("trough zone").</li> <li>The morphology of the mineralised horizon in the eastern limb is well mapped out by drilling and historic mining while the western limb up dip extent is poorly tested and mapped.</li> </ul>
<b>Drill hole Information</b>	<ul style="list-style-type: none"> <li>A summary of all information material to the understanding of the exploration results including a tabulation of the following information for all Material drill holes: <ul style="list-style-type: none"> <li>easting and northing of the drill hole collar</li> <li>elevation or RL (Reduced Level – elevation above sea level in metres) of the drill hole collar</li> <li>dip and azimuth of the hole</li> <li>down hole length and interception depth</li> <li>hole length.</li> </ul> </li> <li>If the exclusion of this information is justified on the basis that the information is not Material and this exclusion does not detract from the understanding of the report, the Competent Person should clearly explain why this is the case.</li> </ul>	<ul style="list-style-type: none"> <li>Drill hole collar coordinates, elevation, inclination and azimuth, down hole length, interception depth and hole length are available in Orion's geological database and are not included in this release.</li> <li>The significant mineralised intersections and the easting and northing of these mineralised intercepts are presented in prior releases.</li> </ul>
<b>Data aggregation methods</b>	<ul style="list-style-type: none"> <li>In reporting Exploration Results, weighting averaging techniques, maximum and/or minimum grade truncations (e.g. cutting of high grades) and cut-off grades are usually Material and should be stated.</li> <li>Where aggregate intercepts incorporate short lengths of high grade results and longer lengths of low grade results, the procedure used for such aggregation should be stated and some typical examples of such aggregations should be shown in detail.</li> <li>The assumptions used for any reporting of metal equivalent values should be clearly stated.</li> </ul>	<ul style="list-style-type: none"> <li>Significant Intersections for the Deep Sulphide Target are calculated by average of assays result &gt; 0.3% copper or 0.5% zinc and weighted by the sample width and specific gravity of each sample.</li> <li>Significant Intersections for the +105 Level Target are calculated by average of assays result &gt; 0.3% copper or 0.5% zinc and weighted by the sample width of each sample only.</li> <li>In general, the significant intersections correspond strongly to geological boundaries (massive sulphides) and are clearly distinguishable from country rock / surrounding samples.</li> <li>No truncations have been applied at this stage for either Target.</li> </ul>

Criteria	JORC Code explanation	Commentary
		<ul style="list-style-type: none"> <li>Metallurgical samples were composited to form blends for variability testing.</li> </ul>
<b>Relationship between mineralisation widths and intercept lengths</b>	<ul style="list-style-type: none"> <li>These relationships are particularly important in the reporting of Exploration Results.</li> <li>If the geometry of the mineralisation with respect to the drill hole angle is known, its nature should be reported.</li> <li>If it is not known and only the down hole lengths are reported, there should be a clear statement to this effect (e.g. 'down hole length, true width not known').</li> </ul>	<ul style="list-style-type: none"> <li>Most holes intersected the mineralisation perpendicular or at high angle to the attitude of the mineralisation.</li> <li>The geometry of the Deep Sulphide mineralisation is complex and true widths can only be obtained from the three-dimensional wireframe created of the mineralisation.</li> <li>Mineralisation widths have been reported in previous reports.</li> </ul>
<b>Diagrams</b>	<ul style="list-style-type: none"> <li>Appropriate maps and sections (with scales) and tabulations of intercepts should be included for any significant discovery being reported. These should include, but not be limited to a plan view of drill hole collar locations and appropriate sectional views.</li> </ul>	<ul style="list-style-type: none"> <li>Appropriate diagrams (plan, cross section and long section) are shown in the release text.</li> </ul>
<b>Balanced reporting</b>	<ul style="list-style-type: none"> <li>Where comprehensive reporting of all Exploration Results is not practicable, representative reporting of both low and high grades and/or widths should be practiced to avoid misleading reporting of Exploration Results.</li> </ul>	<ul style="list-style-type: none"> <li>All metallurgical test results referred to in the release are listed in Tables 1,2 and 4. All other metallurgical and drill hole information have been detailed in previous releases as referred to in the text.</li> <li>The Company has presented all available information in this report in a balanced manner and has provided appropriate context for the Exploration Results to allow a considered and balanced judgement of their significance.</li> </ul>
<b>Other substantive exploration data</b>	<ul style="list-style-type: none"> <li>Other exploration data, if meaningful and material, should be reported including (but not limited to): geological observations; geophysical survey results; geochemical survey results; bulk samples – size and method of treatment; metallurgical test results; bulk density, groundwater, geotechnical and rock characteristics; potential deleterious or contaminating substances.</li> </ul>	<ul style="list-style-type: none"> <li>Hardcopy maps are available for a range of other exploration data. This includes mine survey plans, geological maps, airborne magnetics, ground magnetics, electromagnetics, gravity and induced polarisation. All available exploration data has been viewed by the Competent Person.</li> <li>The mine operated from 1972 to 1991 and is reported to have milled a total of 45.68 Mt of ore at a grade of 1.11% copper and 2.62% zinc, recovering 0.43 Mt of copper and 1.01 Mt of zinc. Detailed production and metallurgical results are available for the life of the mine.</li> <li>In addition, 1.76 Mt of pyrite concentrates and 8,403 t of lead concentrates as well as amounts of silver and gold were recovered.</li> <li>Copper and zinc recoveries averaged 84.9% and 84.3% respectively during the life of the mine.</li> </ul>
<b>Further work</b>	<ul style="list-style-type: none"> <li>The nature and scale of planned further work (e.g. tests for lateral extensions or depth extensions or large-scale step-out drilling).</li> <li>Diagrams clearly highlighting the areas of possible extensions, including the main geological interpretations and future drilling areas, provided this information is not commercially sensitive.</li> </ul>	<ul style="list-style-type: none"> <li>Further metallurgical testwork is on-going as part of the feasibility study.</li> <li>Plan showing drill hole intersections for metallurgical testwork sample collection is included.</li> <li>List of drill hole identification data for metallurgical samples drill holes is included</li> </ul>